

Revision 0.a Release Date January, 2008
Revision Notes Production release

Technical Specifications Summary

Frequency Range:	87.5 - 108 MHz	Gain:	30dB
P1dB:	3000 Watts CW	Efficiency:	68%
Class:	C	Temperature Range:	0 to 55°C
Supply Voltage:	220VAC, 1 Phase	Max VSWR:	3:1

Amplifier General Description

The SCA series of solid state power amplifiers offer high reliability and full set of standard features. Designed to be driven from a 10W FM Broadcast Quality Exciter, the SCA3000-FM series will deliver up to 3000W output in a compact 5-U + 1-U EIA 19" rackmount cabinet. This amplifier is offered with a hot swappable power supply unit with a single redundant power supply.

Standard features include automatic power control, predictive automatic fan fail detection, VSWR monitoring and automatic foldback, graceful power degradation, serial data communications and control, analog outputs for power, voltage, current (soft configurable), complete front panel information screens. The amplifier features SCA firmware which allows for operation even in the event of circuit fault. This includes damaged power supply, damaged power amplifiers, damaged fans, blocked airflow, VSWR problems.

The power amplifier is based upon sixth generation, +28V DC Silicon LDMOS technology which operates at a DC efficiency of 78% typical! In a standard configuration, this translates into better than 60% system efficiency. Four amplifiers are combined with an isolated broadband combiner, and two power factor correct switching power supplies provide system power.

The chassis uses our oversized military grade heatsink capable of operation beyond most amplifiers. This bonded fin heatsink will allow full power operation at altitude up to 55 °C. Because all RF amplifier sections are sealed from external airflow, outside cooling air may be used saving costly air conditioning requirements. The entire system is built in a modular fashion with all high power components placed in the bottom of the amplifier and power supply, control, low power components in the top of the amplifier. The amplifier maintains an M.T.T.R. (mean time to repair) of better than 60 minutes. For common circuit faults, typical repair time is 25 minutes, and no soldering is required!

Amplifier Picture



Delta RF Technology, Inc.

High Power RF Amplifiers and Accessories

350 South Rock Boulevard • Reno • NV • 89502 • USA

Phone +1.775 DELTA RF [775 335 8273]

Fax +1.775 DELTA FX [775 335 8239]

website: <http://www.drft.com>

email: sales@drft.com

Parameter	Min	Typ	Max	Units	Notes
Frequency	87.5		108	MHz	
Pout	500		3000	W, CW	
Output VSWR			2:1		For full rated power delivered
Output VSWR			3:1		Power gracefully reduced from 2:1
Maximum VSWR			5:1		Amplifier is disabled above this VSWR
Power Input	5	10	25	W, CW	
Gain	14		25	dB	
Gain Variation			±1	dB	ALC off, over frequency
Vsupply		26.5		V, DC	Internal Module Supply Voltage
Drain Current			190	A, DC	
Efficiency	73	80		%	Module - DC to RF
Input VSWR			1.5:1		
Insertion Phase Variation		±5		°	Unit to unit
Spurious Emissions		-80	-60	dBc	
Harmonics		-70	-60	dBc	After LPF

All specifications valid for 50 Ω load

Parameter	Min	Typ	Max	Units	Notes
Form Factor	19" IEC Rackmount Cabinet 6U Height 24" Depth				Including handles, Connectors
Weight		124		lbs	
Operating Temperature	0		55	°C	Derate Max Operating Temperature to 45°C linearly from 10000 Ft to Max
Storage Temperature	-20		85	°C	
Altitude	0		12000	Ft ASL	
Relative Humidity	5		95	%	Non condensing
Shock	Designed to meet MIL-810-C Method 516.2 Proc 2				
Vibration	Normal Truck Transport				
Control Connector	DB-9 Female				Control, Communications, Status
Mains AC Connector	HBL-30				
RF Input Connector	N-Female				Optional 7/16 DIN RS 232. Optional 10 Base T Ethernet
RF Output Connector	7/8 EIA Flange				
Interface - Data	DB-9 Female				
Interface - Analog	3 x Pluggable Terminal Block				
Monitor	BNC-Female				Optional Accessory



Parameter	Value	Units	Notes
Operating Voltages	180 - 264	V AC	Single Phase, 47 - 63 Hz
Maximum Power Consumption	5000	W	
Maximum Current	25	AAC	At 220V, protected with 20A Ckt Breaker
Maximum Input Power	25	W, CW	For normal operation at max power
Maximum Input Power	70	W, CW	No amplifier damage
Load mismatch survival	∞ : 1		

Parameter	Min	Typ	Max	Units	Notes
Detector Type	Logarithmic Amplifier, RMS				
ALC Modes	Constant Gain (ALC Disabled)				
	Constant Power				
Input Attenuator Range	0 - 14dB, continuous				
Forward Power Increment		5		Watts	
Forward Power Accuracy		± 25	± 50	Watts	3000W, 50 Ω
Reflected Power Increment		5		Watts	
Reflected Power Accuracy		± 12	± 25	Watts	300W, 50 Ω
Input Power Accuracy		± 1.0		dB	
Forward Power Trip - Hardware	3100		3150	Watts	50 Ω
Reflected Power Trip - Hardware	300		350	Watts	Referenced to 50 Ω
Forward Power Trip - Software		3050		Watts	50 Ω
Reflected Power Trip - Software		350		Watts	Referenced to 50 Ω

Amplifier Features:

- RF Modules are easy to service - connectorized RF In, RF Out, Power and IO
- Power supplies are easy to service - slide out from single connector
- Simple wiring harnesses, all modules have connectors
- Sealed RF compartments - no airflow over RF electronics
- Multiple interface options, including RS232, Ethernet, Analog and Digital I/O
- Broadband Operation - no tuning required for frequency change
- Simple calibration routines
- All functions available by remote control and front panel operation



Front View

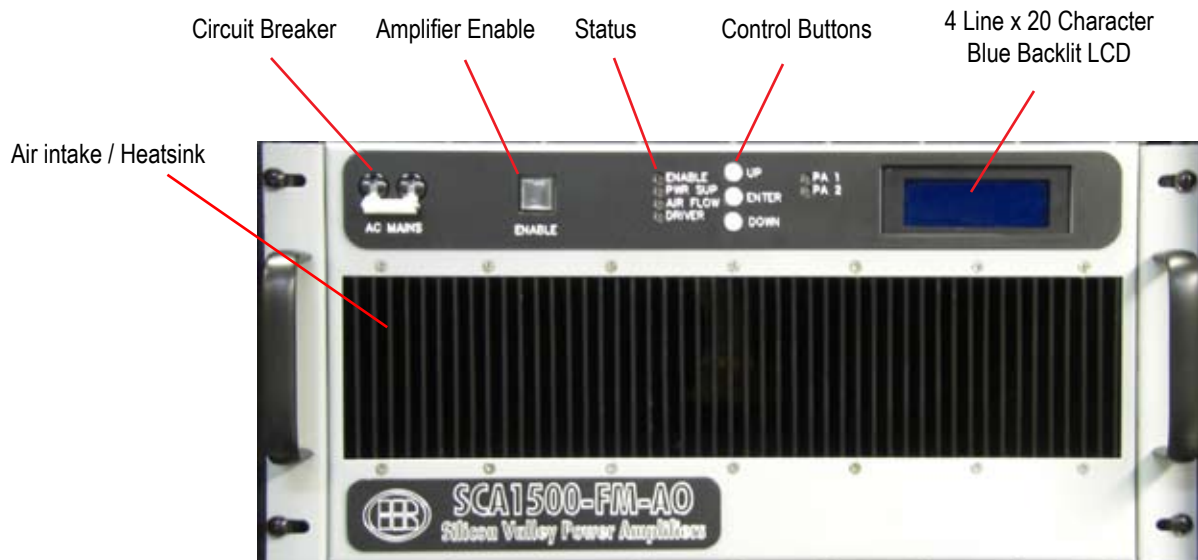
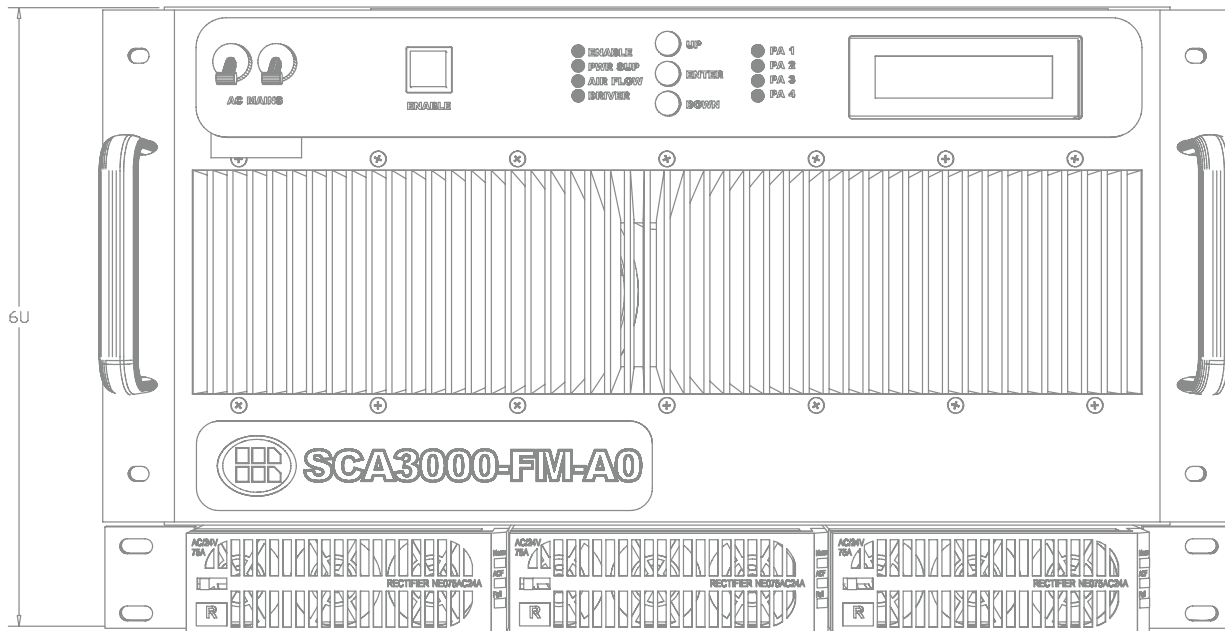

LED Status Indicators:

- Enable: Green Active, Red Off, Amber Warning Condition
- Power Supply: Green Active, Red Fault
- Air Flow: Green Fans ok, Amber Fan Problem, Red Fans Failed
- Driver: Green Drive ok, Amber Drive hi / lo, Red No Drive
- PA x: Green: Active, Amber - Overtemp or Current, Red: Failed

AMPLIFIER ENABLE BUTTON:

Always lights red and indicates 'OFF' when circuit breaker is off or switch is in off position.
When Circuit Breaker is ON and switch is in on position, lights green and indicates 'ON'

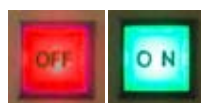

Top View

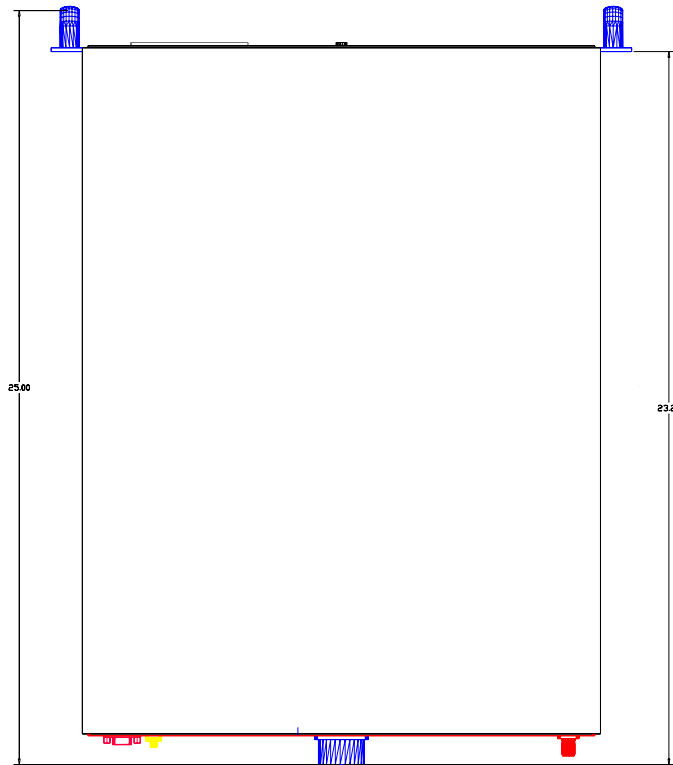

Rear View

J101: Interlock	
J101 - 1	Interlock, Ground to enable
J101 - 2	Ground
J102: Relay	
J102 - 1	Normally Closed
J102 - 2	Common
J102 - 3	Normally Open
J103: Auxillary	
J103 - 1	Voltage PS-1, 1V/10V, nom 2.65V
J103 - 2	Voltage PS-2, 1V/10V, nom 2.65V
J103 - 3	Current PS-1, 1V/20A
J103 - 4	Current PS-2, 1V/20A
J103 - 5	OPTION, User Selectable
J103 - 6	Ground
J103 - 7	TTL: 3dB down (1/2 power)
J103 - 8	TTL: Power Out Down, 10W Increment
J103 - 9	TTL: Power Out Up, 10W Increment
J103 - 10	TTL: Amplifier Disable
J103 - 11	TTL: Amplifier Enable
J103 - 12	TTL: FAULT output

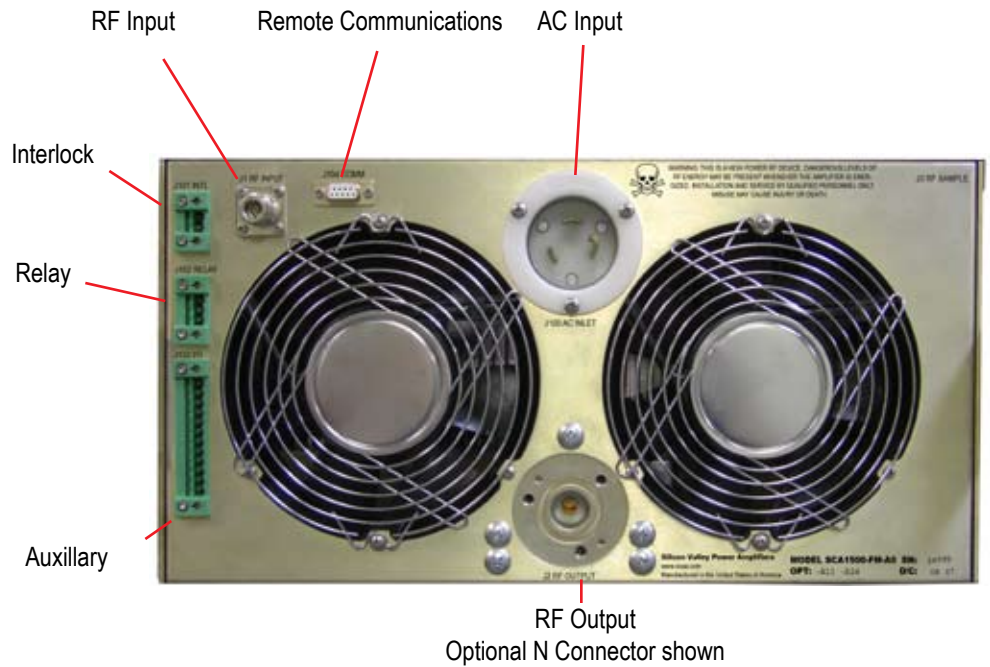

Top View

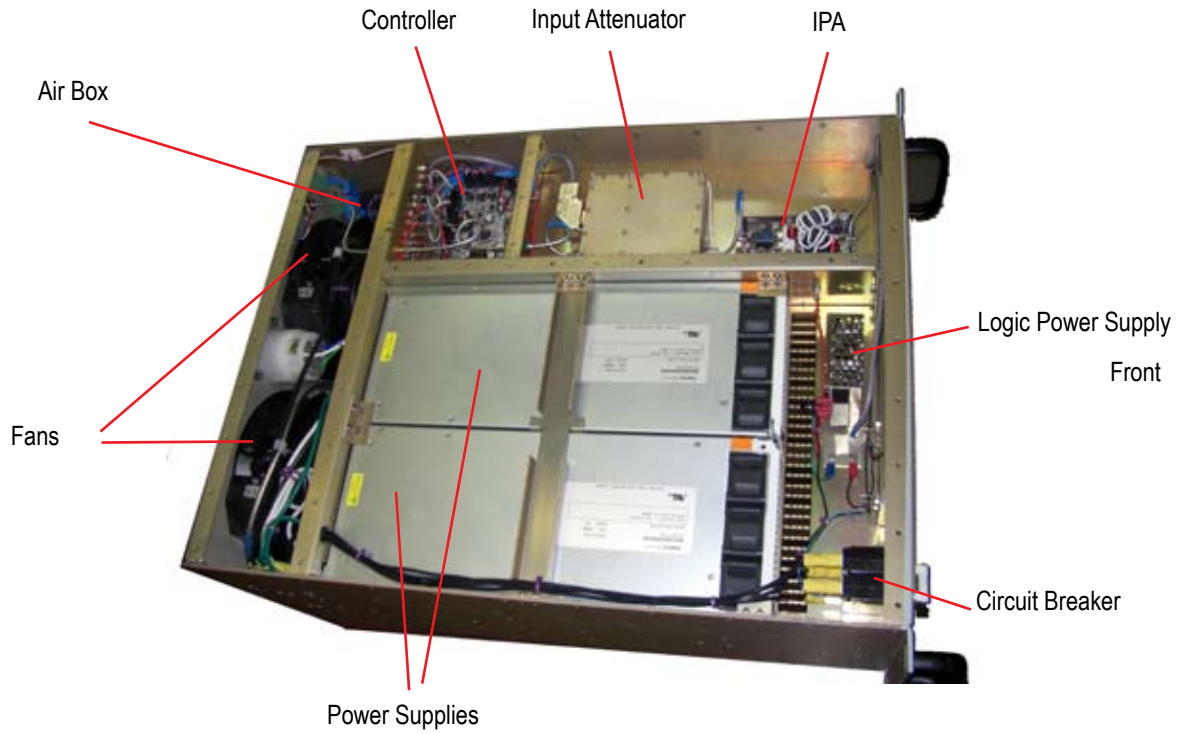

Bottom View

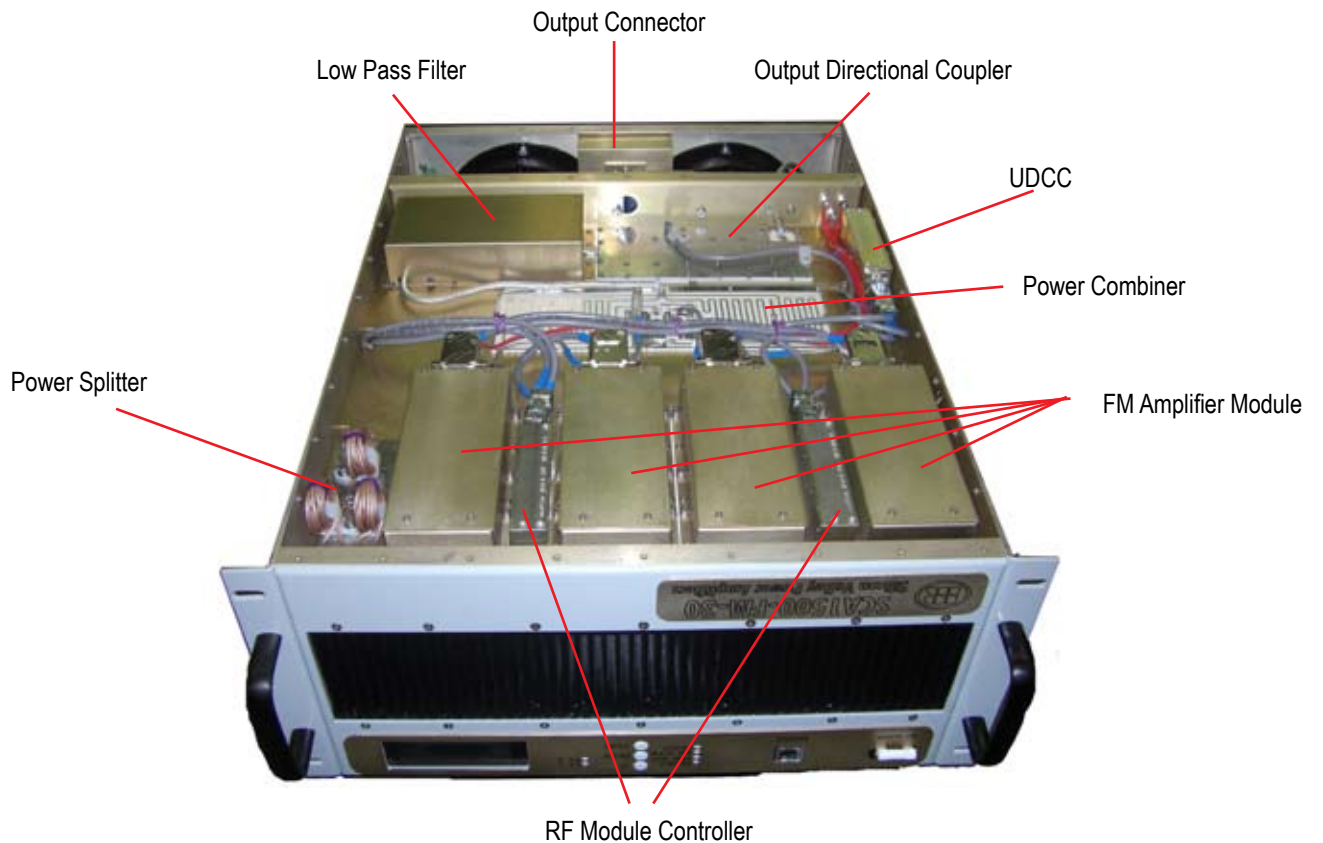

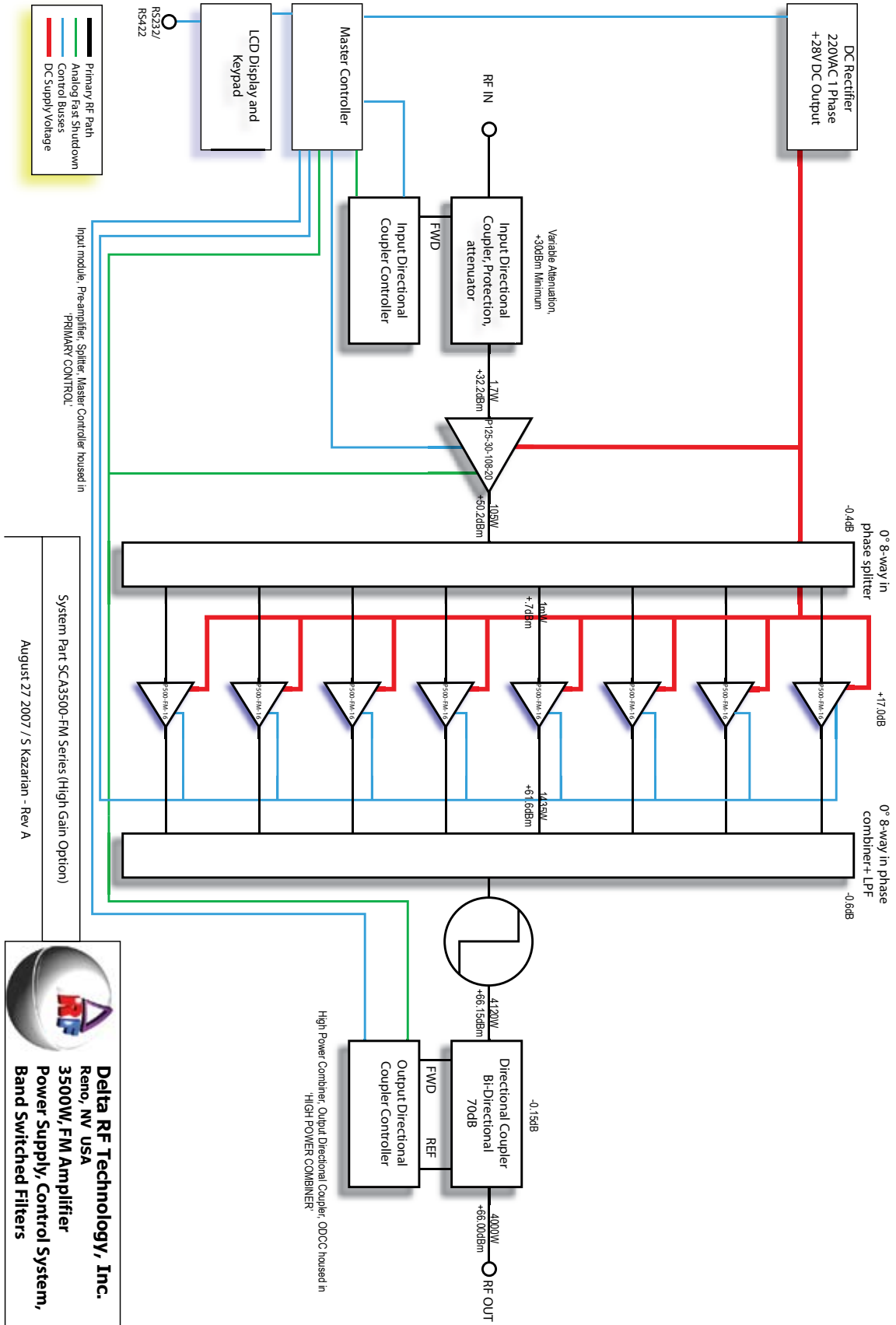

System Part SCA3500-FM Series (High Gain Option)
August 27 2007 / S Kazarian - Rev A



Delta RF Technology, Inc.
Reno, NV USA
3500W, FM Amplifier
Power Supply, Control System,
Band Switched Filters



Amplifier Functional Description:

The SCA amplifier series is designed to deliver power at all costs. The power will be reduced if necessary to keep amplifier on the air. All functions and errors are logged and may be monitored from the amplifier or remotely.

High Temperature at Pallet Amplifiers or Combiner

Within 20° of maximum operating temperature, reduce output power to halt increasing temperature. Once temperature decreases below threshold, return power to set level. If temperature exceeds maximum, disable RF amplifiers, attempt restart at 30 second intervals or immediately upon temperature reduction

High VSWR:

Slowly reduce output power to keep VSWR under limits, up to 5:1. At 5:1, disable amplifier (requires operator intervention). If hardware trip is reached as in the event of a catastrophic failure, power is automatically reduced 3dB and operator intervention is required.

Low Exciter Input:

Increase RF Amplifier Gain to reach desired power. If RF input is still insufficient, signal alert, but keep amplifier operational.

High Exciter Input:

Decrease RF Amplifier Gain to maintain desired power. If RF input is still too high, disable amplifier. (requires operator intervention)

Dead Pallet Amplifier:

Reduce maximum output power to safe level, alert operator, keep amplifier operational.

Fan failure (total) or blocked airflow:

Within 20° of maximum operating temperature, slowly reduce output power to halt increasing temperature. Once temperature decreases below threshold, return power to set level.

If temperature exceeds maximum, disable RF amplifiers, attempt restart at 30 second intervals or immediately upon temperature reduction.

10 Failed password attempts through remote port:

Disable remote functions, requires front panel operator intervention.

AC Power Fail

Amplifier will automatically restart and provide RF within 10 seconds of AC restoration, unless UPS option is selected in which case RF power will remain as long as UPS has power. The amplifier can be user programmed to stay off in the event of power failure.

Power supply voltage out of range:

Reduce power to preset level for safe pallet operation at new voltage. Disable and restart power supply to attempt to clear fault.



PAB Controller Description:

The PAB series controller is a microcontroller based system that uses embedded local controllers to monitor all amplifier functions and operations. The system is designed to keep the amplifier on the air and offer complete status reports and self diagnosis.

How do I control the amplifier?

Two methods - through the front panel and through the RS232 or optional ethernet interface.

The front panel interface includes a 20 character x 4 line display, and front panel mounted push button keys. All amplifier parameters can be reviewed and set and all status events can be reviewed. The front panel interface also includes a remote lockout so the amplifier can not be accidentally powered when under maintenance or repair. When the amplifier enable button is in 'OFF' mode, the amplifier will not turn on even if power is requested.

The remote interface, whether RS-232 serial or optional ethernet interface, offer complete amplifier control and may be operated simultaneously with the front panel interface. Even if RF is inhibited through front panel interface, or the Remote Lockout is activated, the remote interface will still provide status information and also provide status of the safety switches.

What can I set on the amplifier?

- RF Enable - RF Power may be turned on and off.
- Power Level - Output power may be set. Depending on user mode selected, output power may be set in Watts, or as % of total power, or in steps using the analog rear panel interface.
- Power Fail Mode - Control whether the amplifier re-enables or goes directly to standby mode after an AC Power Failure.
- Directional Coupler Calibration - may be set against a known good power meter.

```
Power Out: 0 W
Ref Power: 0 W
Int. Temp: 23°C
Op Time: 0H 36M
```

What can I monitor on the amplifier?

- RF Power - including Forward Power, Reflected Power, Input Power
- Power Supply AC Voltage - Presence of acceptable AC Voltage
- Power Supply DC Output Voltage- Voltage of power supply is monitored both at the output of the power supply and locally at the RF amplifiers
- Power Supply DC Current - Power supply current is monitored at each RF pallet amplifier.
- Temperature - temperature of every RF pallet amplifier, heatsink, combiner
- Fans - fan operation - both predictive and full stall

```
PS 1 Volts: 27.22 U
PS 1 Current: 0.12 A
PS 2 Volts: 27.13 U
PS 2 Current: 0.12 A
```

```
PA 1 Volts: 27.21 U
PA1A Current: 0.06 A
PA1B Current: 0.06 A
PA 1 Temp: 21°C
```

```
PA 1 Temp: 21°C
PA 1 SN: 17815
PA 2 Volts: 27.13 U
PA2A Current: 0.06 A
```

```
PA 2 Temp: 22°C
PA 2 SN: 17815
Int. Temp: 23°C
Sys SN: 18327
```

What self tests are performed?

Upon every startup, power supply function, individual RF pallet amplifier function, processor and embedded controllers, combiner are all checked.

During normal operation, Pallet Amplifier Operation, Power Supply Operation, Combiner, External Connections are constantly monitored. The controller will provide troubleshooting to the module level and can identify faults with the following modules: RF Pallet Amplifier, Driver, Power Supply, Combiner, Input Module.

What is displayed on the front panel of the amplifier?

6 LED's show amplifier status. All green, amplifier is enabled and operational. LED's show status of Amplifier, Fans, Power Supply, Driver, RF Pallet Amplifiers. LCD Display is used for monitoring and data entry:

Expert Mode: Power output Watts, Reflected Power Watts, Input Power Watts, Uptime days, hours, minutes. User can also choose scrollable display which includes every parameter monitored by the amplifier.

User Mode: RF Power Out - % total power, amplifier Status (OK / ALERT)

Can the amplifier operate in a damaged state?

RF Pallet amplifier damaged - the amplifier contains four pallet amplifiers and will provide output power even if up to three amplifiers are non operational.

Fan failure - amplifier power will be reduced to keep operation within safe levels. Even if temperature eventually exceeds absolute maximum ratings, amplifier will automatically re-enable when temperature falls below threshold.

What security protections are included?

Front panel security includes optional system password and user passwords. User password can be used to enter detailed amplifier functions but not allow changes to output power. The same passwords are required for remote operation but add a failed password attempt lockout that must be cleared through the front panel. Expert / User modes are set from the front panel only and require the system password.



PAB Series Controller, Continued

Remote Control Functions:

- ◆ ON - Enables Amplifier when in REMOTE mode. If amplifier is in LOCAL mode, this function will give an error.
- ◆ OFF - Disables Amplifier, and resets error condition
- ◆ STATUS - Displays complete amplifier and module status, including power levels, voltages, currents, temperatures
- ◆ LOG - lists last log entry
- ◆ LOG xx - lists xx log entries, up to 1000
- ◆ LOGOUT - If password function is enabled through front panel, logs user out of the controller.

Sample Remote Control Communications Session:

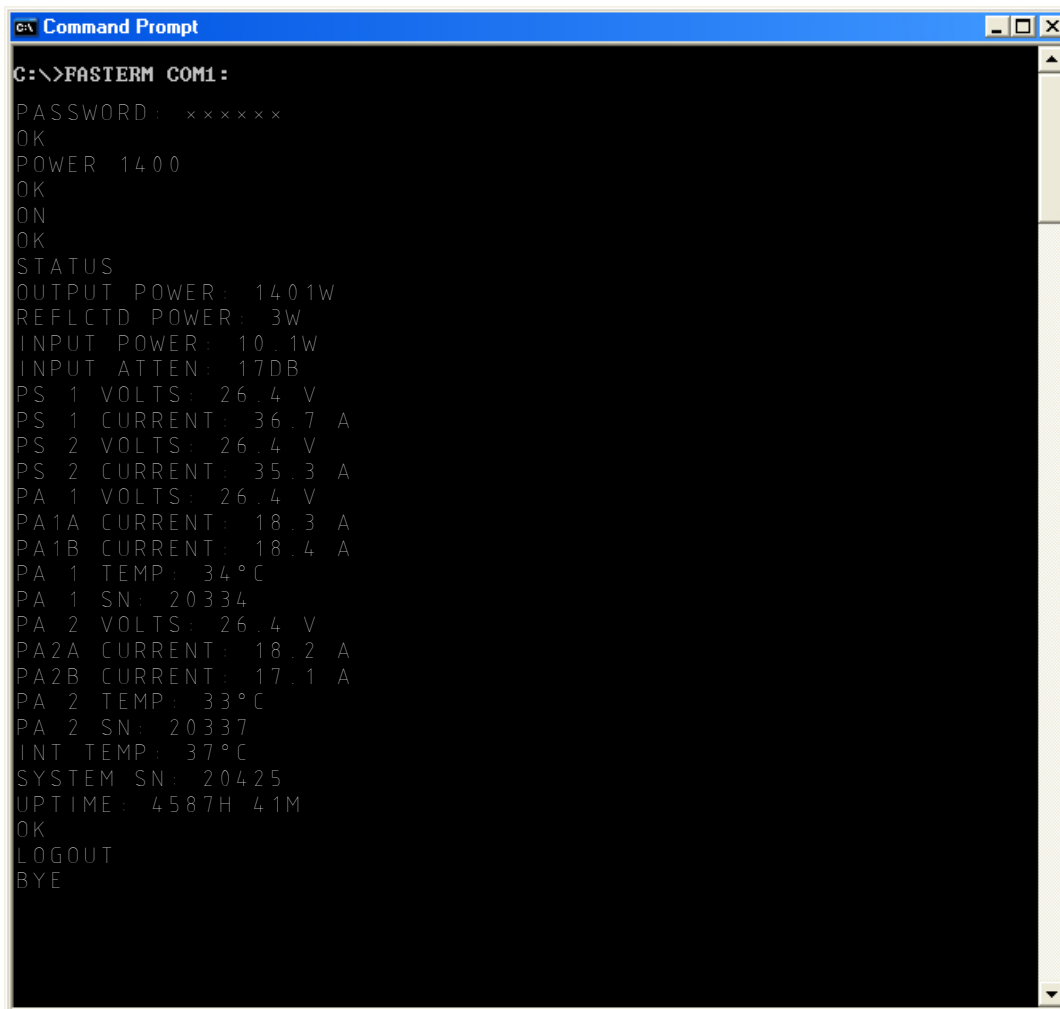

```
C:\>FASTERM COM1 :
PASSWORD : x x x x x x
OK
POWER 1400
OK
ON
OK
STATUS
OUTPUT POWER: 1401W
REFLCTD POWER: 3W
INPUT POWER: 10.1W
INPUT ATTEN: 17DB
PS 1 VOLTS: 26.4 V
PS 1 CURRENT: 36.7 A
PS 2 VOLTS: 26.4 V
PS 2 CURRENT: 35.3 A
PA 1 VOLTS: 26.4 V
PA1A CURRENT: 18.3 A
PA1B CURRENT: 18.4 A
PA 1 TEMP: 34°C
PA 1 SN: 20334
PA 2 VOLTS: 26.4 V
PA2A CURRENT: 18.2 A
PA2B CURRENT: 17.1 A
PA 2 TEMP: 33°C
PA 2 SN: 20337
INT TEMP: 37°C
SYSTEM SN: 20425
UPTIME: 4587H 41M
OK
LOGOUT
BYE
```



Ordering Information:

Order Code	Description	DRFT Reference
SCA3000-FM-A0	3.0kW Broadband Self Contained Amplifier with LPF and PS For use with 5 - 25W Exciter Power	5191
SCA3000-FM-A1	3.0kW Broadband Self Contained Amplifier with LPF, and PS High Gain Option for 1W - 10W exciters	5192
Configuration		
-A17	Substitute BNC Female RF Input Connector [N Female is standard]	0207
-A25	Substitute 7/16 DIN Female Output RF Connector [7/8 EIA Flange Female Connector Standard]	0215
-A35	Substitute N Female Output RF Connector [7/8 EIA Flange Female Connector Standard]	0225
Options		
-A19	Ethernet Communications (replaces RS-232)	0209
-A24	Add Drawer Slides	0214
-A43	Add Rear Panel Monitor Port, -50dB	0233
-A42	Add Front Panel Monitor Port, -50dB	0232
-A26	UPS and Batteries for One Hour Operation, full power, Four hour operation, reduced power	0216
-A31	Phone / voice interface Autodial with problem report and amplifier identification.	0221
-A37	Add 1U external Power Supply rack for hot swap power supplies	0227
-T2	Extended Burn In	0271
-T3	Extended Data Collection	0272
-S	Ethernet Based Software Monitoring Program, Windows XP/Vista	xxxx

Testing Options:

Standard - includes power test and brief burn - in under laboratory conditions. Printed test report gives graph of Gain and Input Return Loss at rated P1dB and Voltage Conditions. Report shows pass/fail criteria. All amplifiers include this test.

Extended burn in - 8-hour burn in at P1dB with standard test run at completion. Unit is monitored during test and any discrepancy reported. Standard test data is included.

Extended data collection - Standard data is run and included. Detailed data is taken point by point giving the customer 25 - 70 frequency points, depending on the amplifier model. For each frequency point, data is generated to include gain, input power, input return loss, current, second harmonic, third harmonic, efficiency, audio distortion.

Other tests available - Vibration, Temp cycling, Shock. Please inquire.

Warranty Statement:

All transmitters and optional accessories will be covered against manufacturer's defects, defects in construction, for a period of two years from date of shipment. Transmitter failures due to overdrive, overtemperature operation, excessive VSWR, improper operation, acts of God are not covered under this warranty. Warranty repairs will be performed on complete amplifiers or amplifier systems. Repairs will be granted on component level only after authorization by the factory. Exception: Main Power Supplies, including UPS option, are covered under their manufacturer's separate warranty.

All shipping charges are the responsibility of the customer. This is an abbreviated warranty statement. Please consult the factory for complete details.

The specifications contained herein are subject to change without notice. Delta RF Technology, Inc. assumes no liability for the use of this information. This data sheet and contents are the property of Delta RF Technology, Inc. © Delta RF Technology, Inc. 2008.

